

# 34MD Series Motor / Driver Combination

SPEC SHEET

- **Step Motor / Microstep Driver Combination**
- **Eliminates Motor Wires**
- **Compact Package**
- **20-80V Power Requirement**
- **Optically Isolated Inputs**
- **Ideal for Precise Positioning**
- **0.180° Resolution per step**
- **Efficient and Durable**
- **Long Life Expectancy**
- **RoHS Compliant**



The 34MD Series is a compact construction that implements a microstepping driver and a step motor in one streamline package. With the two parts combined into one casing, the need to include motor wires has been eliminated. The 34MD Series has an output current capability of 1.5 Amps minimum to 10.0 Amps maximum (Peak Rating). The microstepping driver will operate off 20VDC minimum to 80VDC maximum. The inputs are optically isolated with a minimum sourcing of 1.0 mA per input (+3.5VDC minimum to +8.6VDC maximum). The clock input is set to receive either positive or negative edge clocks with a maximum frequency of 100KHz. The microstepping driver features a resolution of 2000 steps/revolution, providing smooth rotary operation. The 34MD series comes in motor stack lengths of 1, 2, or 3 allowing for varying amounts of start-up torque and inertia. The 34MD series features include built in over current and short circuit shut down, automatic 50% reduction in current after clock pulses stop being received, and status LED's to indicate power on (green LED) and clocks being received (yellow LED).

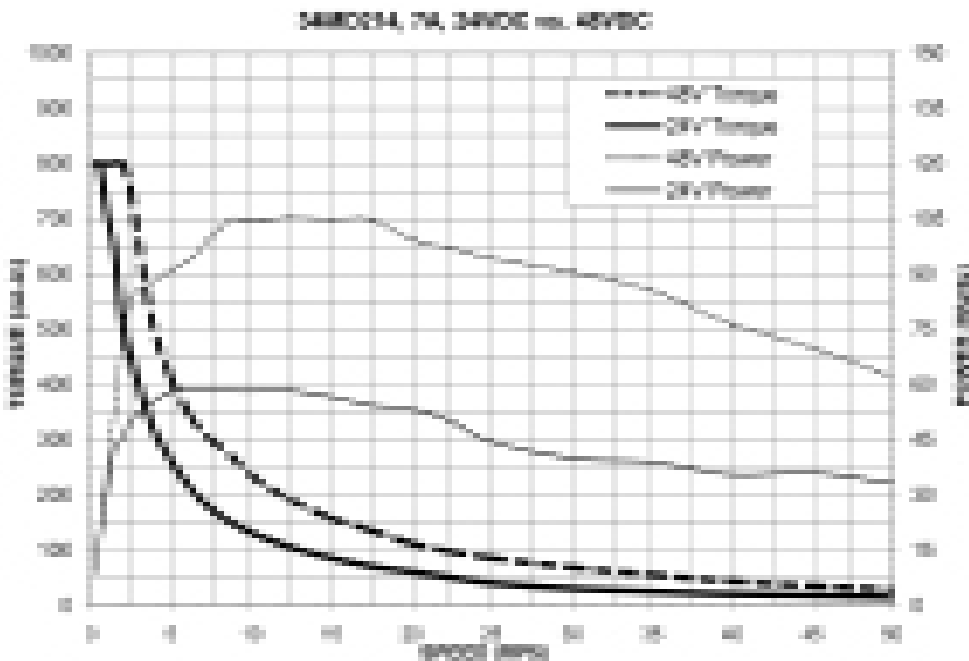

Figure 1: 34MD214S torque speed curve



**ANAHEIM AUTOMATION**

910 East Orangefair Lane, Anaheim, CA 92801  
e-mail: [info@anaheimautomation.com](mailto:info@anaheimautomation.com)

(714) 992-6990 fax: (714) 992-0471  
website: [www.anaheimautomation.com](http://www.anaheimautomation.com)

# Optically Isolated Input Pin Descriptions

The inputs of the 34MD Series are optically isolated with the anode (+) and cathode (-) both brought out to the user. With no current going through the opto-diode the input is considered high. To enable the input a minimum of 1.0 mA needs to be sourced or sunk through the opto-diode. This is done simply by placing a voltage of +3.5 to +8.6 VDC across the two inputs of the opto-diode. If sourcing current into the inputs, then all three cathodes (-) should be tied together and grounded as shown in Figure 3. If sinking current, then all three anodes (+) should be tied together to the +voltage as shown in Figure 4.

To enable an input, apply a DC voltage source of +5VDC to +8.6VDC across the inputs. The Anodes (+) are pins 1, 3, and 5 and the Cathodes (-) are pins 2, 4, and 6.

## Hook-Up Drawings

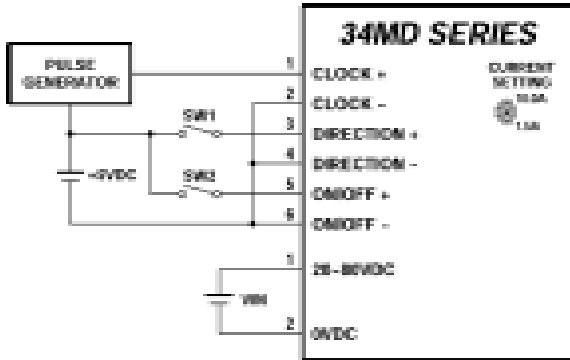

Figure 2: 34MD Series (Sinking Inputs)

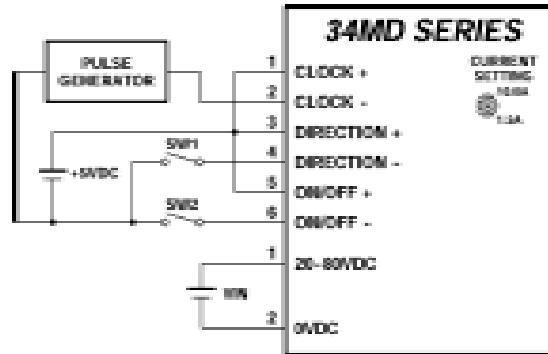

Figure 3: 34MD Series (Sourcing Inputs)

Input Pin Descriptions	
Pin #	Description
1	Clock anode (+)

Table 1: 34MD Input Connector

Power Pin Descriptions	
------------------------	--

Table 2: 34MD Power Connector

## Electrical Specifications

Item	Units		
Input Voltage (Power)	20	80	VDC
Phase Output Current		7.1	A (RMS)

Table 3: Electrical Specifications

- Direction:** Active - CW  
Inactive - CCW
- Clock:** Active - 1 Step  
Inactive (open) - Reduce Current Mode
- On/Off:** Active - Off  
Inactive (open) - On

### Absolute Maximum Ratings

- Input Voltage: 80 VDC
- Output Current: 10.0 AMPS PEAK
- Max Plate Temperature: 80° C
- Storage Temperature: 0° to +50° C

# Dimensions

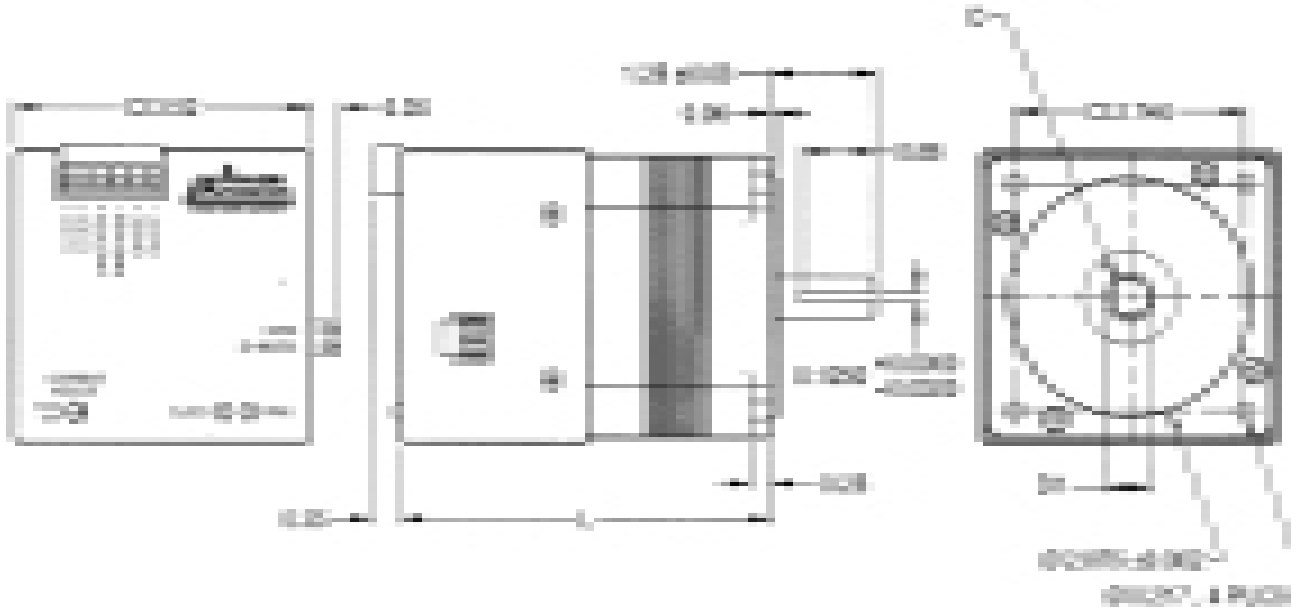

Model	L	D	D1
34MD1123S	5.37"	0.5"	0.555"

Table 4: 34MD Stack Lengths and Diameters

## Power Supply Requirements

It is recommended that the 34MD series be powered by the PSA80V4A or the PSAM48V3.2A. The PSA80V4A is a 80 Volt, 4 Amp power supply that will take either 110 VAC or 220 VAC inputs and deliver 320 Watts. The PSAM48V3.2A is a 48 Volt, 3.2 Amp power supply with a universal input to accept input voltages in the range of 95 - 265VAC and deliver 150Watts.

## Power Supply Drawings for PSA80V4A and PSAM48V3.2A

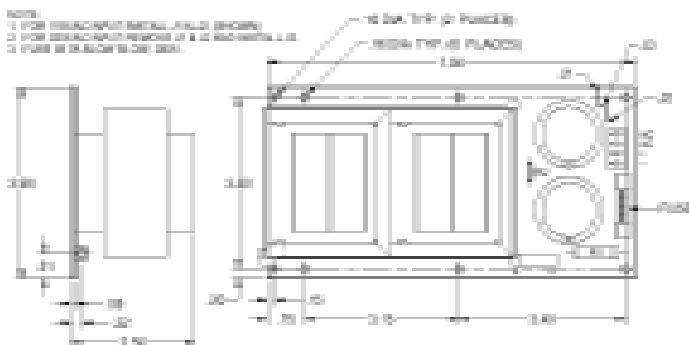

Figure 5: Dimensions for PSA80V4A

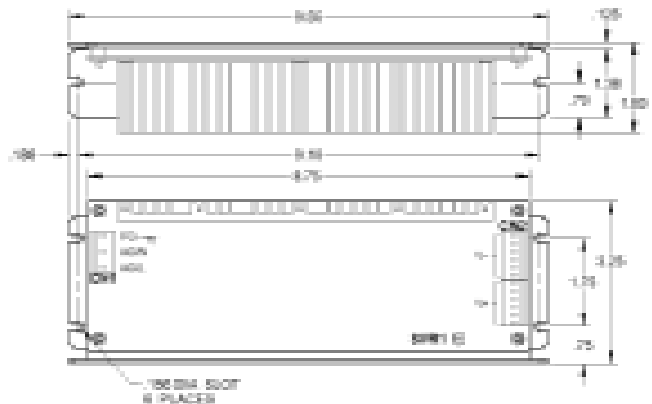

Figure 6: Dimensions for PSAM48V3.2A

## Setting the Output Current

**WARNING:** When using a higher current setting into a motor, the motor will overheat and burnup. Should this occur, the driver will also be damaged. Use additional airflow and heatsinking to keep motor and driver temperature under 80° C.

The output current on the 34MD Series is set by an onboard potentiometer. This potentiometer determines the per phase peak output current of the driver. The relationship between the output current and the potentiometer value is as follows:

Peak Current	Potentiometer Setting	Peak Current	Potentiometer Setting
1.5A	0%	7.0A	60%
2.3A	10%	7.9A	70%
3.1A	20%	8.7A	80%

Table 5: Potentiometer values with respect to the output current

## Reducing Output Current

Reducing the output current occurs approximately 1 second after the last positive going edge of the step clock input. The amount of current per phase in the reduction mode is approximately 50% of the set current. Reducing the output current is accomplished when no current flows through the opto-diode at the CLOCK (+) and CLOCK (-) pins after the last step has occurred. The clock LED should be off at this time.

## Determining Output Current

The output current for the stepper motor being used when microstepping is determined differently from that of a full/half step unipolar driver. In the 34MD Series, a sine/cosine output function is used in rotating the motor. The output current for a given motor is determined by the motors current rating and the wiring configuration of the motor. There is a current adjustment potentiometer used to set the output current of the 34MD Series. This sets the peak output current of the sine/cosine waves. The specified motor current (which is the unipolar value) is multiplied by a factor of 1.0 due to the motor configuration in series.

**WARNING:** When using a higher current setting into a motor, the motor will overheat and burnup. Should this occur, the driver will also be damaged. Use additional airflow and heatsinking to keep motor and driver temperature under 80° C.